

# Gas Ball Valve



## 2 Piece • Male Dielectric Union End x Flare Connections • 600 WOG



**T-204DU**

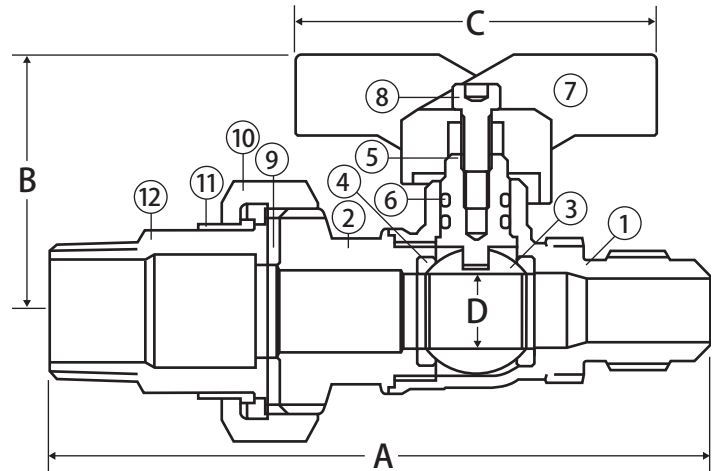

### Features

- Meets the NFPA 58 dielectric requirement
- Valve can be locked in the closed position by reversing the handle
- 2 Viton® o-rings
- 100% leak tested
- 100% Made in Italy
- Leakproof stem - Lifetime Warranty

### Approvals

- CSA Certified
  - ANSI Z21.15 (.5 PSIG) (1/2")
  - ASME B16.44 (5 PSI) (1/2")
  - CGA CR91 (5 PSIG) (1/2")
- ANSI B1.20.1
- Meets or exceeds applicable part of UL: YSDT - LP Gas Shut-off valves (600PSI)
- MSS SP-110
- Flare Connection in accordance with NFPA 54/ANSI Z223.1

### Material Specifications

No.	Part	Materials
1	Body	Brass - CW617N
2	End Connection	Brass - CW617N
3	Ball	Chrome Plated Brass - CW614N
4	Seat (2)	PTFE
5	Stem	Brass - CW614N
6	Stem O-ring (2)	Viton®
7	Handle	Aluminum
8	Handle Screw	Steel - Geomet® Plated
9	Gasket	Buna-N
10	Union Nut	Brass - CW617N
11	Dielectric Ring	Nylon 6
12	Tail Piece	Brass - CW614N

### Dimensions

Part No.	Size	A	B	C	D
101-703DU	1/2" MIP x 1/2" FL	4.32	1.63	2.32	0.47
101-704DU	3/4" MIP x 5/8" FL	4.77	1.75	2.32	0.59

### Valve Seat Rating 600 WOG

