

Lockwing

Utility Gas Ball Valve • Full Port • 175 PSIG with Insulated Tail Piece



Brass



Painted

175-LWIN

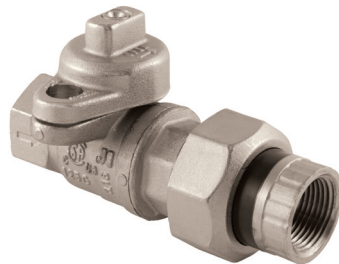

T.E.A. Coated

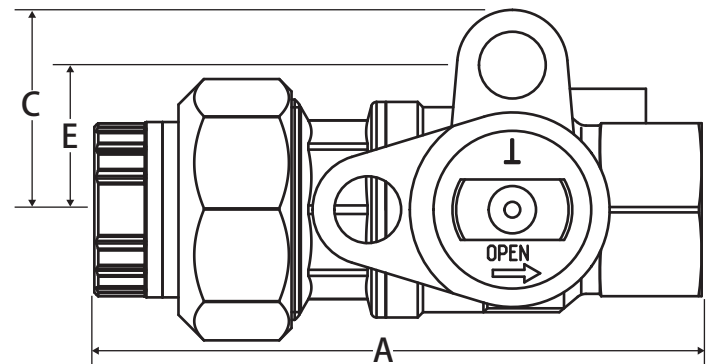
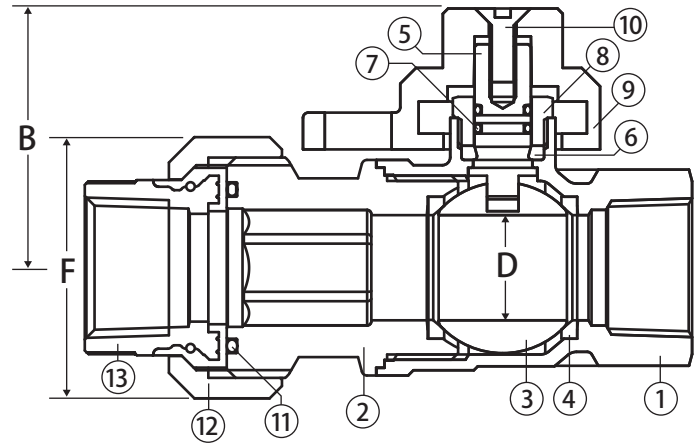

Features

- Tamper resistant locking cap
- 2 Viton® o-rings
- Full port design to accommodate industry leading stop changers
- Lockwing accommodates standard barrel locks
- Maintenance free design
- 100% leak tested
- 100% Made in Italy
- Leakproof stem - Lifetime Warranty

Approvals

- CSA Certified (3/4" - 1")
 - CGA 3.16 (125G)
 - ANSI B16.33 (125G)
- Meets or exceeds applicable part of DOT 192
- MSS SP-110

Pressure Rating

- 175 PSIG
- Temp range: -40°F to 300°F



WARNING: This product can expose you to chemicals including lead, which is known to the State of California to cause cancer, and lead, which is known to the State of California to cause birth defects or other reproductive harm. For more information go to www.P65Warnings.ca.gov.

Material Specifications

No.	Part	Materials
1	Body*	Brass - CW617N
2	End Connection*	Brass - CW617N
3	Ball	Chrome Plated Brass - CW617N
4	Seat (2)	Hostaflo® TFM 1600
5	Stem	Brass - CW614N
6	Packing	Buna-N
7	Stem O-ring (2)	Viton®
8	Packing Gland	Brass - CW614N
9	Lockwing Cap*	Brass - CW617N
10	Screw	304 Stainless Steel
11	Union O-ring	Viton®
12	Union Nut*	Brass - CW617N
13	Insulated Tail Piece*	Zytel® / Brass - CW614N

*Component may be T.E.A. coated or AGA painted depending upon selection

Dimensions

Part No.	Size	A	B	C	D	E	F
241-004_	3/4"	4.58	1.87	1.50	0.79	1.08	1.81
241-005_	1"	5.49	2.15	1.73	0.97	1.30	2.40
241-006_	1-1/4"	5.78	2.21	2.00	1.23	1.50	2.57

_ = Specify coating: D = Brass, P = Painted, T = T.E.A. Coated