

Lockwing



Utility Gas Ball Valve • Full Port • Service Bypass • 125 PSIG



125-LWBP

Features

- Tamper resistant lockwing cap
- 2 Viton® o-rings
- Full port design to accommodate industry leading stop changers
- Lockwing accommodates standard barrel locks
- Maintenance free design
- 100% leak tested
- 100% Made in Italy
- Leakproof stem - Lifetime Warranty
- Patented security shutter and lockwing tab
 - US Patent no. 6,648,009

Approvals

- CSA Certified
 - ANSI B16.33 (125G)
- Meets or exceeds applicable part of DOT 192

Pressure Rating

- 125 PSIG
- Temp range: -40°F to 300°F
- MSS SP-110

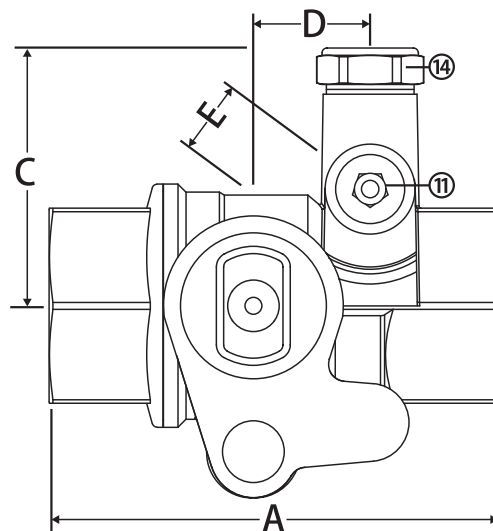
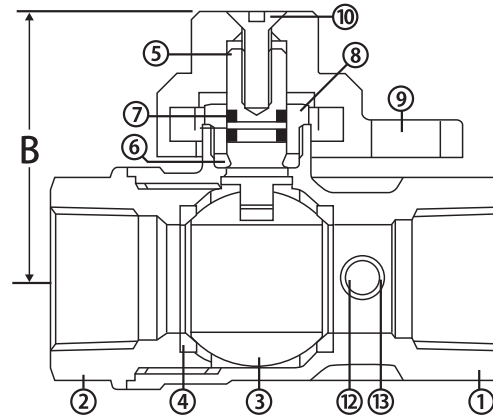

Material Specifications

No.	Part	Materials
1	Body*	Brass - CW617N
2	End Connection*	Brass - CW617N
3	Ball	Chrome Plated Brass - CW617N
4	Seat (2)	Hostaflo® TFM 1600
5	Stem	Brass - CW614N
6	Packing	Buna-N
7	Stem O-ring (2)	Viton®
8	Packing Gland	Brass - CW614N
9	Lockwing Cap*	Brass - CW617N
10	Screw	304 Stainless Steel
11	Bypass Plug*	Brass - CW614N
12	Bypass Set Screw	Brass - CW614N
13	Bypass O-ring	Viton®
14	Bypass Cap*	Brass - CW614N

*Component may be AGA painted depending upon selection

Dimensions

Part No.	Size	A	B	C	D	E
244-005_	1"	3.65	2.21	2.18	0.95	0.59

_ = Specify coating: B = Brass, P = Painted