

THE T-100 JUST GOT BETTER

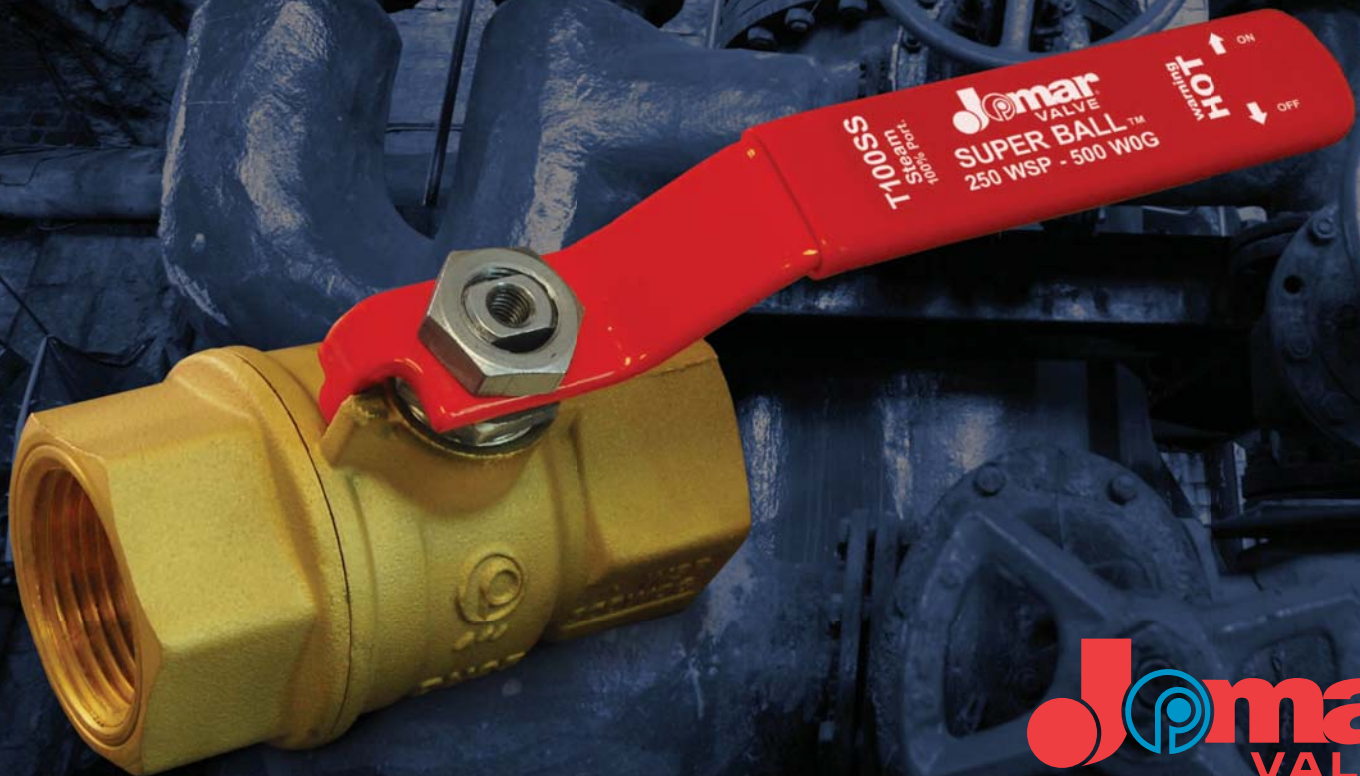

NOW RATED FOR 250 STEAM



	T-100SSS	70B-140	T-585
Full Port	✓		✓
PTFE Carbon Filled Seats (Max Temp = 500°)	✓		✓
Brazed Body-Female Thread	✓		
Stainless Steel Ball & Stem	✓	✓	✓
Stainless Steel Nut	✓		✓
Geomet Steel Handle with Epoxy Coating (Max Temp = 392°)	✓		
2 Viton O-Ring + PTFE G415 Ring on Stem	✓		
Class: WSP250	✓	✓	✓

Description

Steam Valve - 1/4 turn, lever operated, hot forged brass ball valve. 100% full port. Blow-out proof two-piece design. Made in Italy. 100% tested.

Dimensions in Inches

Computer No.	Valve Size	A	B	C	D	E	CV†
100-533	1/2"	2.48	1.24	1.53	0.59	2.95	20.25
100-534	3/4"	2.71	1.36	1.93	0.79	3.74	41.83
100-535	1"	3.30	1.65	2.40	1.00	4.72	78.38
100-536	1-1/4"	3.78	1.89	2.59	1.25	4.72	132.10
100-537	1-1/2"	4.17	2.09	3.22	1.57	5.90	206.96
100-538	2"	5.00	2.50	3.50	2.00	5.90	346.00

† The CV Factor is the gallons of water per minute passed through the valve with a 1 PSI pressure drop.



Body-female thread brazed with special soldering temp up to 392°F. Torque 10 times more than required by asme b16.33

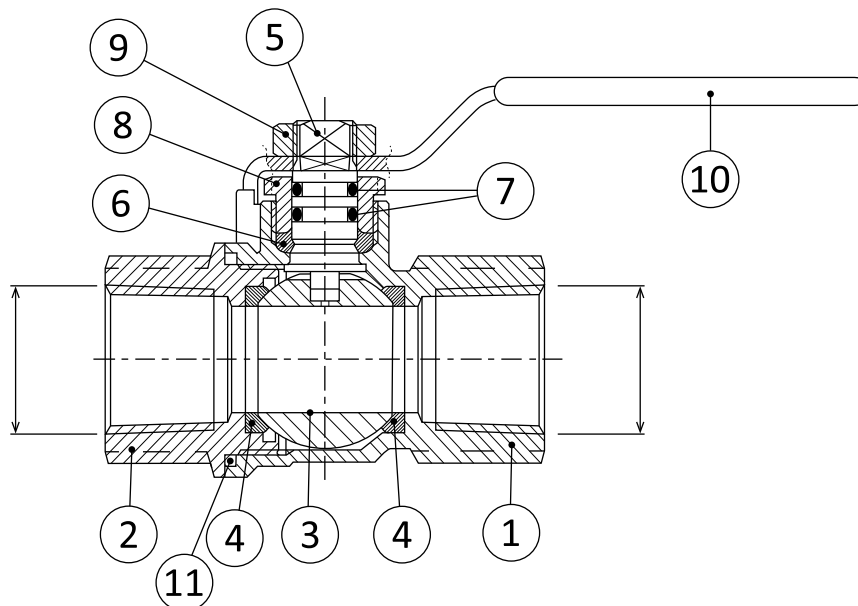

Material Specifications

No.	Part Name	Materials
1	Body	Hot Forged Brass
2	2-Piece End Adapter	Hot Forged Brass
3	Ball	316 Stainless Steel
4	Seat (2)	PTFE Carbon Graphite
5	Stem	316 Stainless Steel
6	Packing	PTFE Carbon Graphite
7	O-Rings, (2)	Viton®
8	Packing Gland	Extruded Brass
9	Hexagonal Nut	316 Stainless Steel
10	Handle	Coated Steel
11	Soldering Alloy	BrazeTec Soldamoll

Pressure Rating

1/2"-3/4"	600WOG - 250 WSP
1"- 2"	500WOG - 250 WSP

